

Pick Up Truck Rear Racks

by
Oak Orchard
Waterport, NY 14571
(closed Tuesdays)

1-800-452-9257

www.oakorchardcanoe.com



New Adjustable Uprights w/ Style #1 and Style #2



Above left: Front mounted Style #3 with 5th wheel trailer.

Lucas and brother Logan showing us how easy car topping can be.

All loads must be properly strapped to the cross bars and long canoes and kayaks, must be tied to the four bumper corners as shown below. We also recommend load stops for canoes or ladders. Foam kayak saddles \$39.95 pr. Front rack locks \$39 pr. For canoe kayak security- 9' locking cable w/lock - \$59.00.

Oak Orchard's Pick up Truck "Rear Racks" can carry two canoes side by side or up to 3 Kayaks side by side or 5 Kayaks on their side. Won't Shake and Sway like flimsy aluminum snap together in the box styles. Our system compliments already the best sport rack in the business . . . Yakima! We use and recommend many Yakima components ourselves. We recommend a half set of a Yakima rack for the "front" of your carry system. This will make for an easy on/off, secure and rigid carry system. We can fit most trucks/cars with or without gutters. Cost for the cab portion of the Yakima system will run around **\$169**. Get a 10% discount on Yakima accessories with a rear rack purchase! Shown below on Sierra with rigid tonneau cover. Upright can remove. Approx 3" of plate will be seen.



There's a Right Way to Do Things . . . and a Wrong Way!

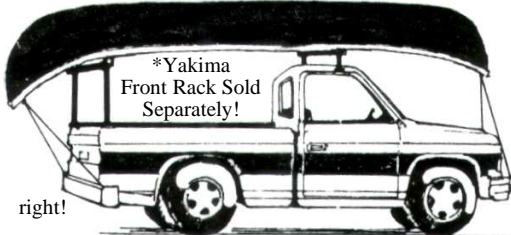

Our competitor's ad shows a 12' Old Town Pack and a 10' kayak on their "in the box" type rack. Even small boats will sway from side to side and scare the heck out of you. These folding style racks won't work if your truck has a tonneau cover or cap. Oak Orchard's style #2 will do the job! Our racks will fit trucks with or without tonneau covers. PowderCoat Black, heavy duty 1" square steel - Easy on-off! Our racks are strong and side sway is limited.

Picture your 16' canoe/kayak w/ "In the Box" systems with little more than 1/2 of your canoe supported properly. Or the "along the side rail folding type" requiring dozens of drill holes and "clamp ons" that will vibrate loose!



* We Can Fit ALL Cars and Trucks *
(with or without over the door rain gutters)

THREE STYLES! ONE IS RIGHT FOR YOUR TRUCK!



Style "1" upright lengths are sized correctly for either compact, mid size or full size trucks.. Uprights can mount to a flange at the tailgate found on some older S10's, Toyota, Nissan, etc., while newer will require the easy mount nut sert installation package. Opt. 78" wide bar - add \$10.00 ea.

Compact Trucks crossbar 66" wide **\$149.95** Flange Mount
Full Size crossbar 66" wide **\$199.95** Nutsert Mount

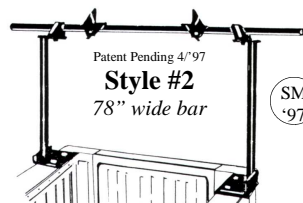

New! CLAMP-ON Style #2
No Drilling - fits under All Tonneau covers.
Style "# 2" uprights adjust to compact sized trucks or full sized trucks fitted with tonneau Covers!

We call this one "the UNIVERSAL" because it fits any truck with or without tonneau covers & caps. Most Camper tops can use the flat "econo" plate, while Tonneau covers require a formed, black Stainless Steel Plate. Plates will mount under the tonneau cover and protrude out from underneath a couple inches and our uprights bolt onto this plate. Black HD steel! Uprights can remove in minutes. The '04 (and newer) F150 (4 big doors) we offer two widths of plates, one width can install back near the tailgate or over the axel.

Flat Plate **\$199.95** for Camper
Clamp on **\$279.95** formed plate

Choice of #2 Side Rail Plates available

Oak Orchard maintains a selection of different sized, shaped top rail plates to fit all trucks with tonneau covers, such as Rangers, Toyotas, Chevys, Fords, etc. with very different side rails, so you can open/close your new tonneau covers easily. New F150 w/4 Big Doors require a left and right plate.

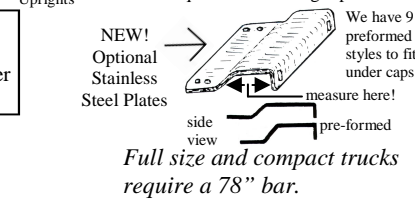

Full size and compact trucks require a 78" bar.

Opt. Nutsert mount kit **\$279.95**
Opt. Tacoma fit using the factory installed track system **\$309.95**

Load brackets shown - \$29 pr. Dlx Style #3

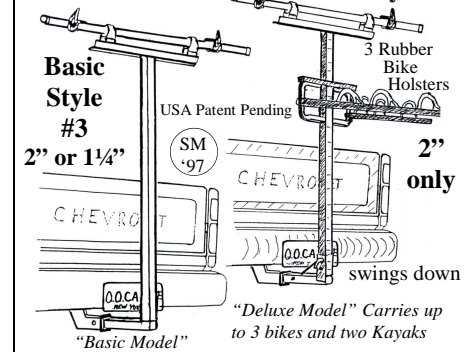

Two inch Receiver (or 1 1/4") is our quickest installing rack and does the job when others won't. Comes complete with a 48" or 58" bar to carry two Kayaks up to 100 lbs. DLX bike model can carry up to 95 lbs. of bikes in rubber holsters (compare to \$500 carriers). Folds down and away from tailgate. Includes 2 straps and a receiver pin that screws into your receiver to reduce slight sway. Cable/Key to secure bikes included.

\$199.95 Basic boat model
\$429.95 Deluxe 3 bikes/boats



Shown: Installed Nutsert Above: Style #1 rear rack and a half set Yakima "Q" tower front.



Kayak Saddles

16" wide \$39.95 pr.
22" wide \$39.95 pr.

New!

Adj. height up-rights

New #2 side rail plate designed to drop under your tonneau or cap cover. (See right) A flat plate fits most camper tops \$199.95 kit. Please measure the width of your side rail across the top.

full view
side view
measure

The Universal #2 Rear Truck Rack is Compatible with All Tonneau Covers & Caps.

"World Exclusive" Bikes & Boats

Style #3 DLX Carrier can carry boats & bikes (2" only)

Adjustable Removable Top - Here

Standard Style #3 is available in 2" or 1 1/4"

Weight 55 lbs
2" Square Steel Yakima top bar 48" or 58"

Fits full size and mid size trucks. Can mount to front of full size trucks with 2" receiver under front bumper!

Includes connection pin anti-sway bar
Quick remove pin to swing away anti-sway wedge crank
Locking cable to secure bikes

DLX \$429.95

Basic \$199.95

Deluxe Bike/Boat model includes connecting pin!

Connecting pin not included with standard model.

To Order: We will need to know the make, year, model and if you have either a truck cap, or tonneau cover or plan to install either in the near future. If neither of the above is planned then the style #1 is the rear truck rack for you.

* All Oak Orchard Rear Racks are topped off with Yakima bars and components, available from us or any Yakima authorized dealer!

Style #1 truck rack comes complete with one Yakima 66" bar, two Oak Orchard uprights, two aluminum bar connectors with a wrench to establish the correct width, mounting hardware. **\$149.95** (add \$10.00 for 78" bar on full size trucks) Also, shown here is the Yakima 4 pc. gunnel brackets @ \$60.00 set. These stop your canoe from shifting. End tie downs from bumper 'sides' to your load is recommended for ultimate security. Two load straps are also necessary for over your load, connected to your cross bars (add \$20). Some trucks like the Mid Sized Chevy S10 models, Toyota truck (early '90's) do Not Require the Nutsert Option. These vehicles have a Metal "Flange" at the Rear of their Box where the Tailgate Closes Against. Our Uprights can attach to this flange Using the Standard Mounting Hardware included in the **\$149.95** Package. The **#1 Style Deluxe** Rack includes the Nutsert and Flaring Tool Kit @ **\$199.95**. All styles are topped with Yakima bars and accept all Yakima or Thule Rollers & Saddles! Check out our J-Cradles or Gull Wing Saddles!

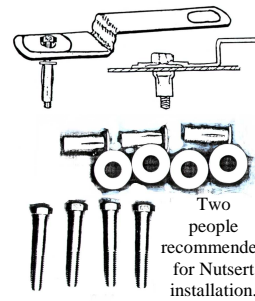

Most new full size and new mid sized trucks will require the deluxe Nutsert system. This includes four Nutserts, four washers, four mounting bolts. You will need one 1/2" wrench or ratchet, one electric drill, drill bits - 1/4" & 1/2". End result is two small threaded holes on each side to mount the uprights. Easy on-off! **\$199.95**

NOTE: Trucks with bed liners, it will be necessary to drill your 1/2" hole thru both the liner and truck sidewall at the same time. Nutserts install into the cavity behind your tail lights. We recommend that the Nutsert be installed through both the liner and steel panel.

Then insert the expanding tool loaded with the Nutsert through both. With the wrench on the Nutsert bolt in one hand and the Nutsert handle in the other, rotate the wrench clockwise holding handle firmly. Much resistance will be felt when completely tightened. When the Nutsert is fully expanded it is necessary to remove the expanding tool by rotating counter clockwise. Repeat!



Style #2. The "UNIVERSAL" RACK fits most flat sided top rails along the top of the truck box. A 5" x 10" plate will mount to the top rail. To this, the uprights will bolt. It's at 'this point' the uprights can be quickly removed, leaving only the plate on the side rails. **Basic Bolt On: \$249.95** Incl. mounting hardware, 2 base plates, 2 uprights, 2 aluminum connectors with set screws, wrench, 78" round cross bar. **Clamp On \$279.95.** Four ViseGrip looking devices will clamp the plate to the under rail (instead of a nut and bolt).

Style #3 Basic - \$199.95 Vehicles with either 2" or 1 1/4" receivers can now carry any small watercraft with the Oak Orchard "T" Rear Rack. Basic model will work on any truck or van with a receiver type draw bar.

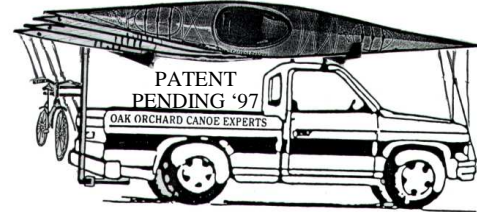

We'll hand craft just the right height rack for your vehicle. Comes standard with a 48" or 58" bar, two deluxe straps to

reduce a slight sway. (We recommend bow/stern tie down straps.) **Deluxe #3 Bike & Boat 2"** receiver. **\$429.95** (Includes "pull pin" to swing down-away from vehicle). Deluxe unit includes a 'receiver pin' that screws into the receiver to reduce sway! Bikes are cradled in deluxe rubber holsters. Includes locking cable with key. Two anti-sway straps. 36 lbs. (S&H \$55.) Our Style #3 Deluxe is truly unique!

Visit our website www.oakorchardcanoe.com